



Disconnecting Downspouts

from the sewer system — safely!



Note: These factsheets are for voluntary improvements by homeowners that are unlikely to need a city permit. You can check permit requirements at DPD Applicant Services: 684-5362, email SideSewerInfo@Seattle.gov

Why disconnect your downspouts from the sewer?

The rain that falls on our roofs, roads, and driveways (called “storm water”) is handled by two kinds of drainage systems. Drains in the street may go to the *stormwater system*, which carries rain water through pipes or ditches to the nearest creek, lake, or Puget Sound. In other parts of Seattle, storm drains carry street runoff into the *combined system*, where rain water is mixed with wastewater from our toilets, showers and sinks, and piped to the sewage treatment plant. During big storms, the combined system can be overwhelmed by excess rainwater, causing a *combined sewer overflow* of mixed stormwater and wastewater into lakes, streams, or Puget Sound.

What does this have to do with downspouts? Some houses in Seattle have their roof gutters and downspouts connected to the combined system. That adds volumes of clean rainwater to the system, which can cause more sewer overflows. Seattle Public Utilities is working hard to reduce sewer overflows, and you can help. Even if your gutters are connected to a storm drain instead of the combined system, disconnecting them can help slow peak flows and reduce stream erosion.

Disconnecting downspouts can help to reduce sewer overflows and protect our streams. But doing it improperly or without considering the questions below could cause you or your neighbors big problems, such as wet basements, flooding, erosion, or landslides.



Before disconnecting, ask yourself these questions:

- ☑ **Does the water have a good place to go?** Direct runoff to a rain garden, cistern, or large lawn or landscape area.
- ☑ **Can it get there?** Provide an adequate pipe, splash block, or swale to convey water away from the house, to the soil.
- ☑ **What happens once it gets there, in a big storm?** Make sure excess runoff can overflow safely to street drains, without flooding your neighbors or sidewalks.

Do:

- **Hire professional assistance if needed**, to advise you or do the work.
- **Know where the water will flow.** Make sure the ground slopes away from your house and your neighbors. You may need to pipe or trench a flow path. — see “Discharge Distances” on reverse.
- **Slow and spread the flow** with a splash block, rock-lined trench, swale, or perforated pipe to prevent erosion and spread water.
- **If possible, provide a place for the water to soak in:** a compost-amended landscape area, rain garden, or rock-filled trench. Cistern overflow pipes should also be directed into a landscape area.
- **Make sure that excess flow from big storms will run to street drains** rather than your neighbors’ property.
- **Inspect your downspout system regularly.**

Don't:

- ✗ **Don't flood neighbors or sidewalks.**
- ✗ **Don't disconnect within 500 feet of steep slopes or landslide-prone areas.** Check your address, with the map layers for known landslide areas, steep slopes and liquefaction zones, at <http://web1.seattle.gov/dpd/dpdqisv2/mapviewer.aspx>
- ✗ **Don't send more than one-half of your roof area** (or up to 700 sq. ft. of roof area) **to any one discharge point** – it's safer to spread it out.
- ✗ **Don't direct flow onto lawns or beds that are sloped more than 15%** (1 foot drop in 7 feet) , because you may cause erosion.
- ✗ **Don't disconnect if water sits at the surface of your yard in the winter** (squishy lawns, springs, puddles) – that means that the ground water level is too high.

Disclaimer: This sheet contains general principles only, which may not be appropriate or safe for every property or project. Use good common sense. You assume the risk and are responsible for all consequences of your modifications to drainage flow or your property, for legal compliance, and for necessary permits and authorizations. The City of Seattle is not responsible for your modifications and disclaims liability for your actions.

How to Disconnect Your Downspout

Tools needed: hacksaw, drill, needle-nosed pliers, screwdriver, tape measure, shovel
Materials: sheet metal screws, standpipe expansion plug or cap, downspout elbow and extension, splash block and/or rocks (see below)



Step 1 Cut downspout pipe

Use a hacksaw to cut off the downspout at least 9 inches above the sewer standpipe that goes into the ground (adjust the cut height to fit your new elbow). Remove the remaining short section of downspout from the end of the sewer standpipe.

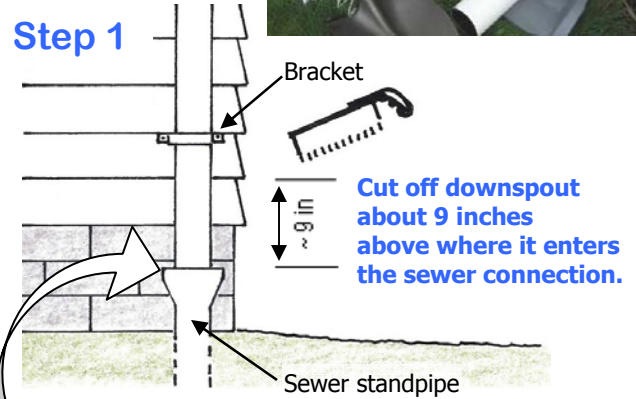

Step 2 Safely plug old sewer standpipe

Use an expansion plug or cap (measure the pipe and ask at hardware store for the right size) to plug the open sewer standpipe. *Never plug the pipe with rags or concrete – they could slip and clog street sewers. And you may want to be able to reverse this job if your yard can't handle all the flow.*

Step 2 Measure and install plug or cap

Step 3 Attach new elbow and pipe to carry downspout flow away from house

Use similar downspout material, or use adapters to change to plastic pipe. If necessary use needle-nosed pliers to crimp the old downspout pipe, so it slides into the new elbow. Drill a hole on either side of each fitting, and screw in a sheet metal screw to secure the fitting. Add a new hanger bracket around the downspout above the cut, if needed to support the downspout and the new elbow and pipe you are adding.

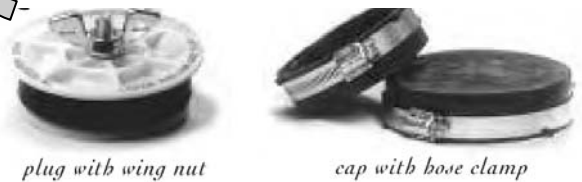

Minimum Discharge Distances

The point of discharge for your new downspout must be a minimum (more is better) of:

- Ⓞ 5 feet from your home, if you have a crawlspace
- Ⓞ 10 feet from your home, if you have a basement
- Ⓞ 5 feet from a property line
- Ⓞ 10 feet from neighboring buildings

and the ground must slope away from buildings and nearby property lines.

To check the slope on nearly level sites: use a level on a long board, or lay a hose on the ground and start it running to see which way the water flows.

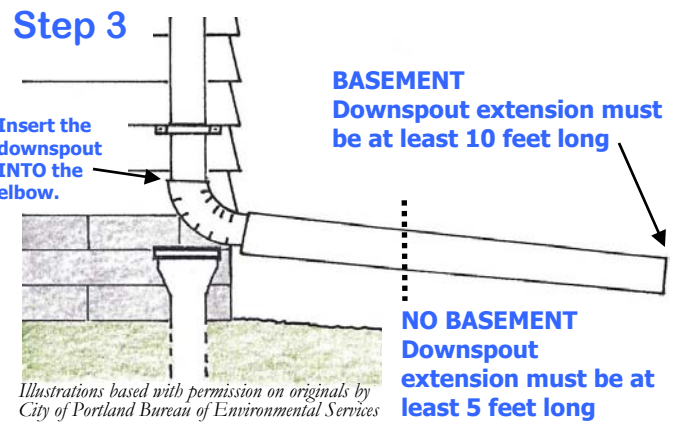

Step 4 Add splash block, rock, or perforated pipe to slow the flow and spread runoff into lawns, beds, a rain garden, or a rock-filled infiltration trench.

In tight locations, you may need to run water through a 4 or 6 inch pipe or a rock-filled trench around a corner, to direct it into a lawn or bed area that slopes away from the house and has adequate size for infiltration. Use a 4-6 inch pipe to convey water under walkways or sidewalks. Don't flood sidewalks, basements, or your neighbors!

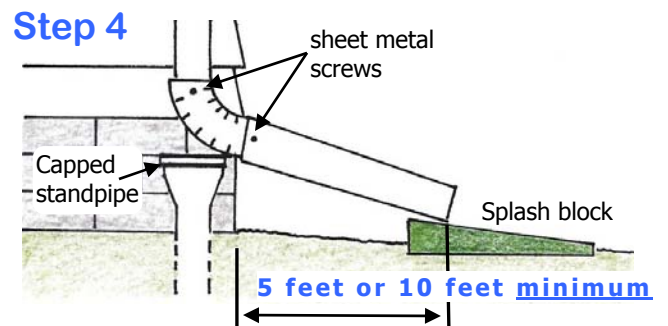

Learn more: For a *Materials and Suppliers* list, fact sheets on Rain Gardens, Cisterns, Rock-filled Infiltration Trenches, Permeable Paving, Improving Your Soil, and other RainWise ideas, see www.seattle.gov/util/rainwise
 For print copies contact the **Garden Hotline** at (206) 633-0224, or email help@gardenhotline.org

Learn more at www.seattle.gov/util/rainwise



Brought to you by

